

2781-A
2781-B
2881-C

Compound type, wedge type V self-lubricating guide plate, VDI3357
复合型，斜楔 V 型自润滑导板，VDI3357



2781-A



2781-B



2881-C

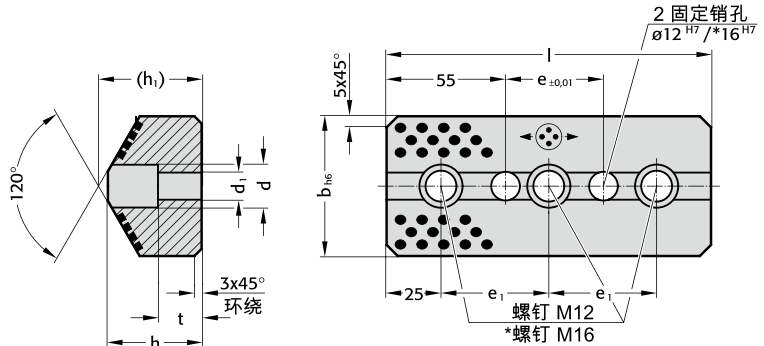

Material: 材料:

2781-A: 钢铸黄铜 + 固体润滑剂 (镶嵌型) Steel cast brass + solid lubricant (set type)

2781-B: 钢烧结铜合金 + 固体润滑剂 (弥散型) Steel sintered copper alloy + solid lubricant (dispersion type)

2881-C: 钢烧结铁镍合金 + 固体润滑剂 (弥散型) Steel sintered iron-nickel alloy + solid lubricant (dispersion type)

2781-A./2781-B./2881-C Compound type, wedge type V self-lubricating guide plate, VDI3357
2781-A./2781-B./2881-C 复合型，斜楔 V 型自润滑导板，VDI3357

b	h	(h1)	l	e	e ₁	d	d1	t	螺栓孔数量
65	44	(47)	150	45	100	20	13.5	20	2
65	44	(47)	200	95	150	20	13.5	20	2
65	44	(47)	250	145	100	20	13.5	20	3
65	44	(47)	300	195	125	20	13.5	20	3
125	47	(52)	150	45	100	26	17.5	15	2
125	47	(52)	200	95	150	26	17.5	15	2
125	47	(52)	250	145	100	26	17.5	15	3
125	47	(52)	300	195	125	26	17.5	15	3
125	52	(57)	150	45	100	26	17.5	15	2
125	52	(57)	200	95	150	26	17.5	15	2
125	52	(57)	250	145	100	26	17.5	15	3
125	52	(57)	300	195	125	26	17.5	15	3

Order 订购	Catalog No. 目录号	b	l	h	材质
	2781	. 065	. 150	. 044	- A
	2781	. 065	. 150	. 044	- B
	2881	. 065	. 150	. 044	- C